



# Nelsen NRO ROC-3HE

## *System Controller Documentation*



# Table of Contents

<u>Table of Contents</u>	<u>Description</u>	<u>Page</u>
Specifications, Table 1		1
Schematic, Figure 1		2
Field Wiring Diagram, Figure 1.1		3
Controller Overview, Figure 2		4
Controller Detail: CPU-4		5
Controller Detail: TB-6		6
Conductivity Probe Installation, Figure 5		7
Controller Programming: Accessing Hidden Menus, Figure 6		8
System Start-up w/Permeate Flush		8
Controller Programming: Program Selections, Table 2		9
Controller Programming: Parameters Explained, Appendix A		10-11
Controller Fault Displays		11-12
Controller Programming: Programming Interface Overview		13
Warranty		14

## Table 1 - Specifications

### Inputs

Tank level switches (2)	Normally-Closed. Can be used with a single level switch.
Inlet pressure switch	Normally-Open.
Pretreat lockout switch	Normally-Open.
High Pressure switch	Normally-Open.
Controller Power	100-240 VAC, 60/50Hz (Switching power supply automatically adjusts)
Permeate Conductivity	0-3000 PPM, 0-6000 $\mu$ s (standard sensor, CP-1, K=.75)
Feed Conductivity (opt)	0-3000 PPM, 0-6000 $\mu$ s (standard sensor, CP-1, K=.75)

### Output Relay Ratings *(relays are fused with a 6A fuse)*

Feed Solenoid	0.5A. Voltage is the same as motor/supply voltage.
Flush Solenoid	0.5A. Voltage is the same as motor/supply voltage.
Motor Contactor Coil	0.5A. Voltage is the same as motor/supply voltage.
Motor Contactor	
ROC-2XHE-20	20A Definite Purpose Contactor: 3.0 HP @ 208-240V.
ROC-2XHE-40	40A Definite Purpose Contactor: 5.0 HP @ 208-240V.

### Circuit Protection

Main/Relay Power Fuse	F1	5x20mm	6 Amp	Littelfuse 0234006P
Power Supply/CPU Fuse	F2	5x20mm	0.125 Amp	Littelfuse 0218.125P

### Other

Dimensions	7" tall, 7" wide, 4" deep. Nema 4X Polycarbonate Hinged Enclosure.
Weight	2.7 lb.
Environment	0-50°C, 10-90%RH (non-condensing)

# Figure 1 - Simplified Schematic

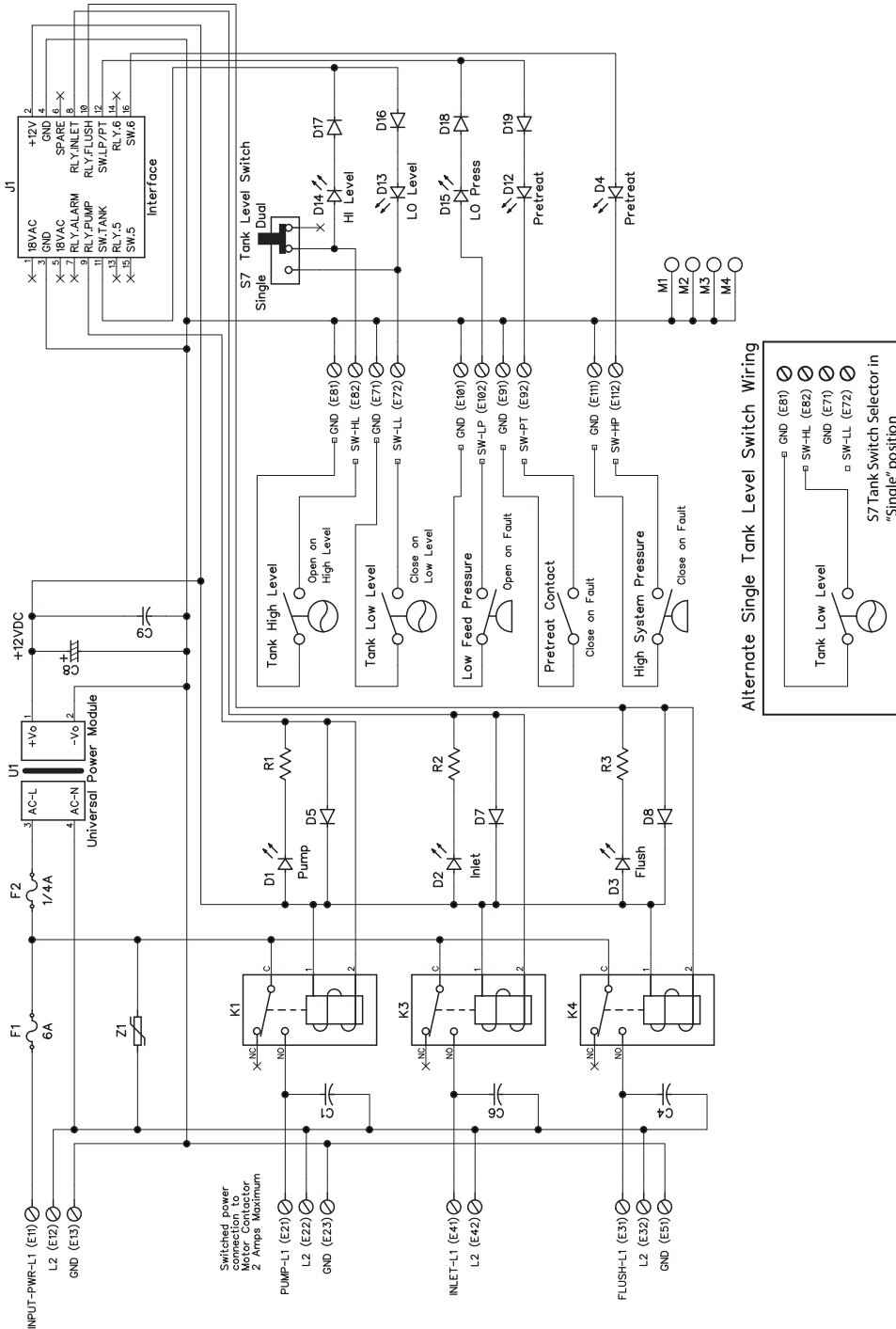

iControls TB-6 Schematic, REV: B (June 2017)

# Figure 1.1 - Field Wiring Diagram

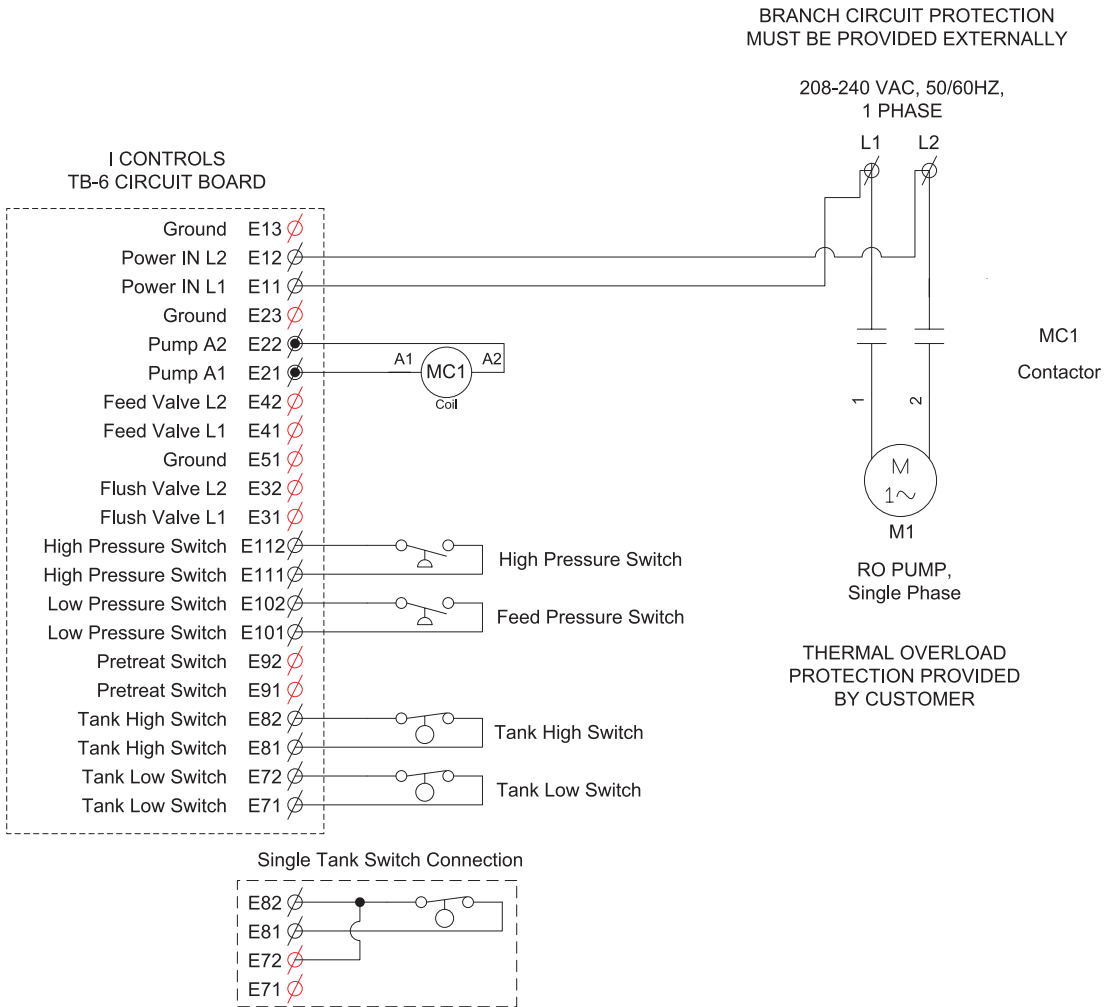

Model #	Ref Des	Description	Manuf/Part Number	Max Motor HP @ 240V 1P
ROC-3HE-20	MC-1	RO Pump Motor Contactor	LS GMC-202P, 220Vcoil	3 HP
ROC-3HE-40	MC-1	RO Pump Motor Contactor	LS GMC-402P, 220Vcoil	5 HP

Program: CPU-4.xml (default)

Fuse#	Value	Type	Description	Where Used
F1	6A	5x20mm	Littelfuse 234006 or equiv.	TB-6
F2	0.125A	5x20mm	Littelfuse 218.125 or equiv.	TB-6

**Figure 2 - Controller Overview**

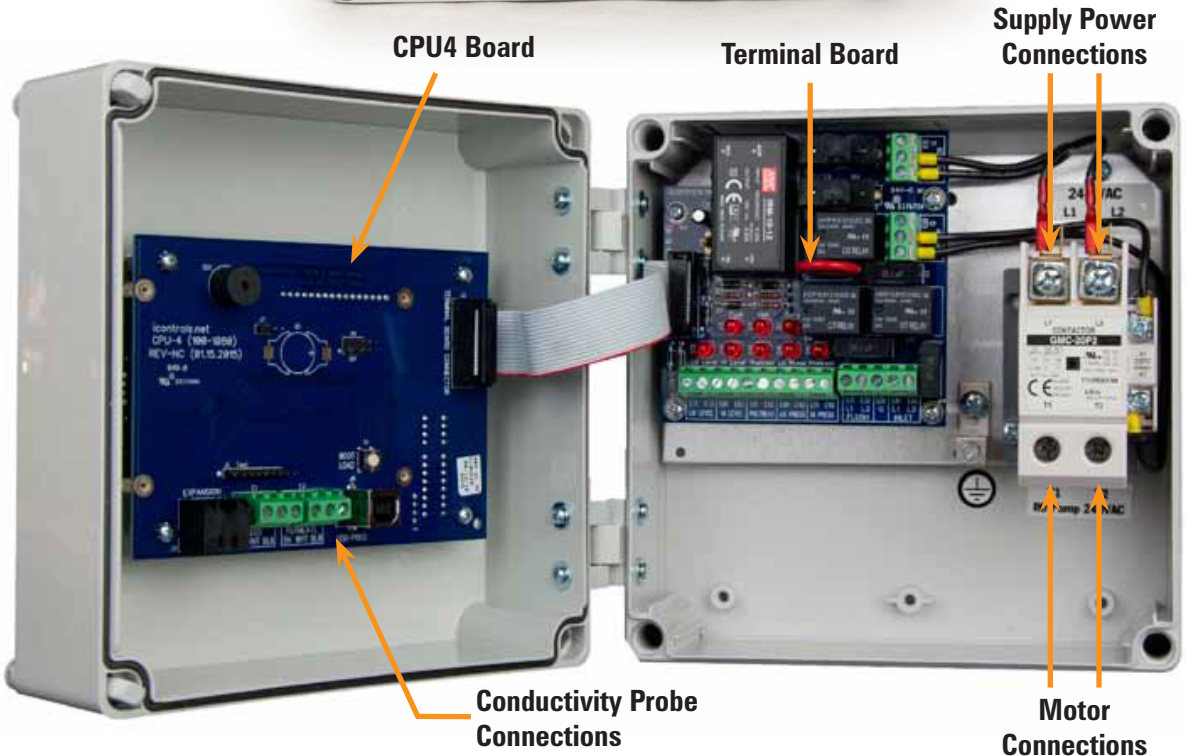
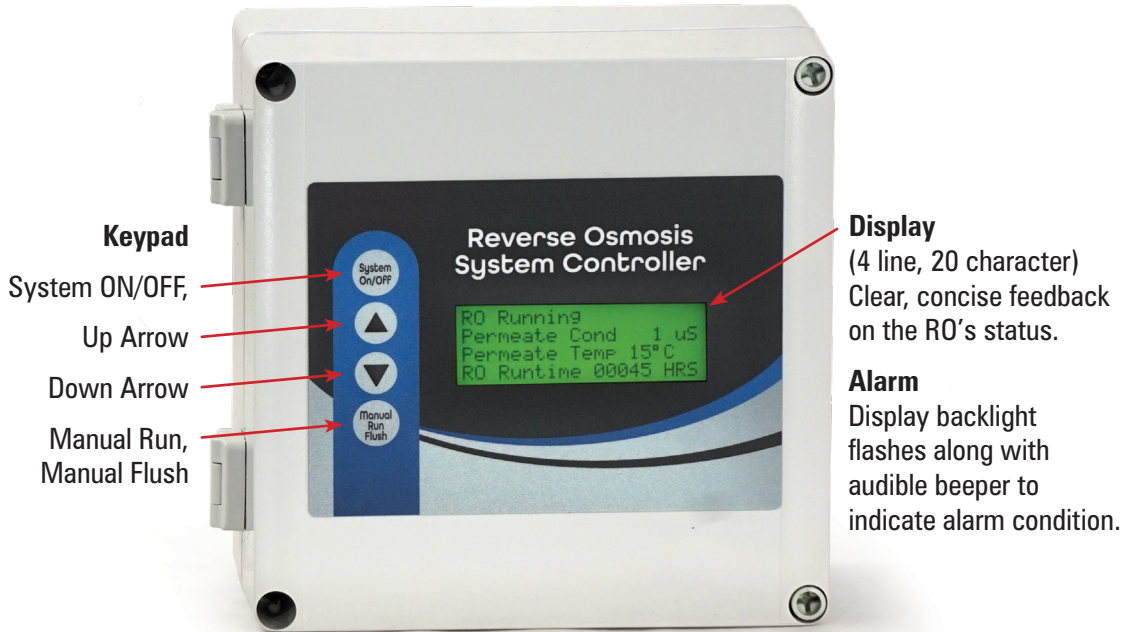

# Figure 3 - Controller Detail: CPU-4

## Typical Configuration

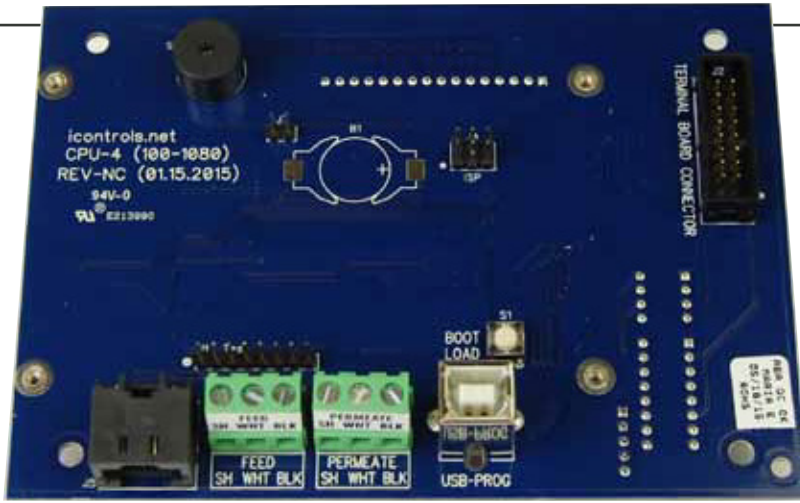

## Typical Configuration

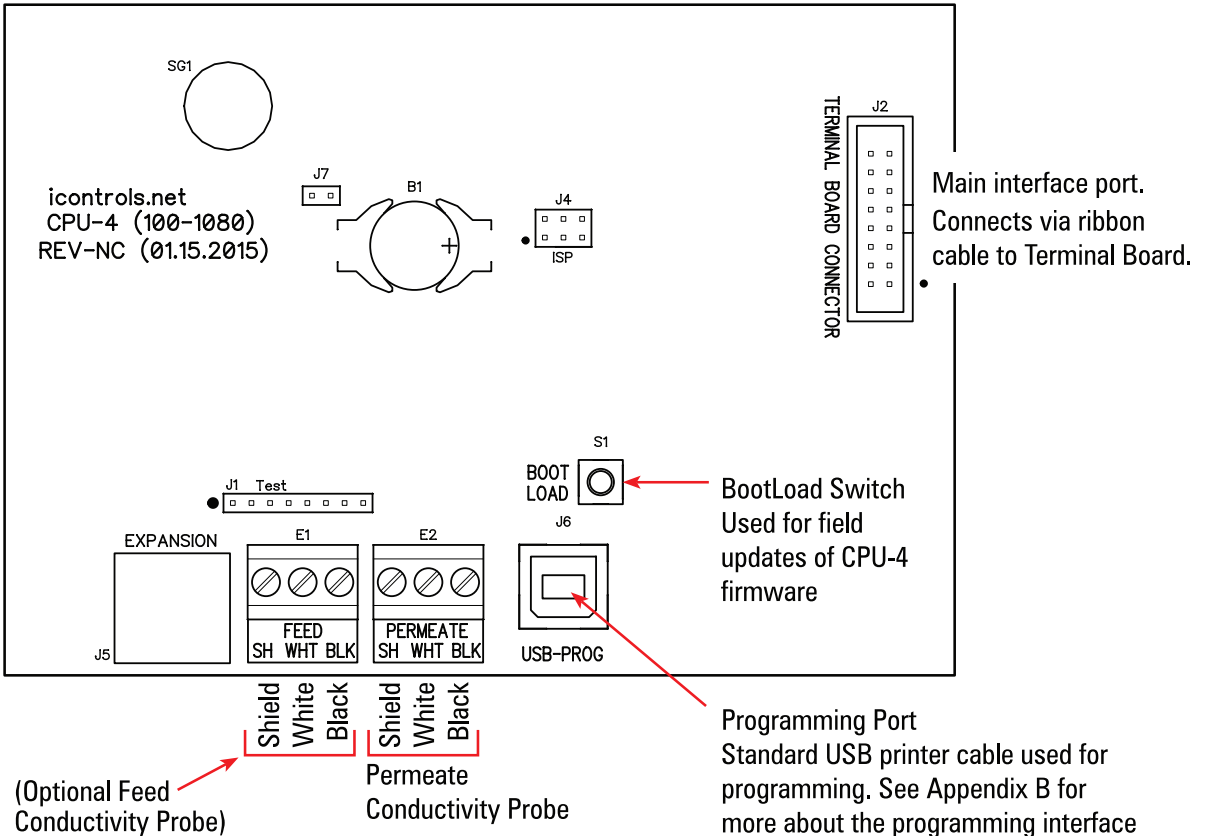



**Figure 4 - Controller Detail: Terminal Board, TB-1 (See Fig. 1 for schematic)**

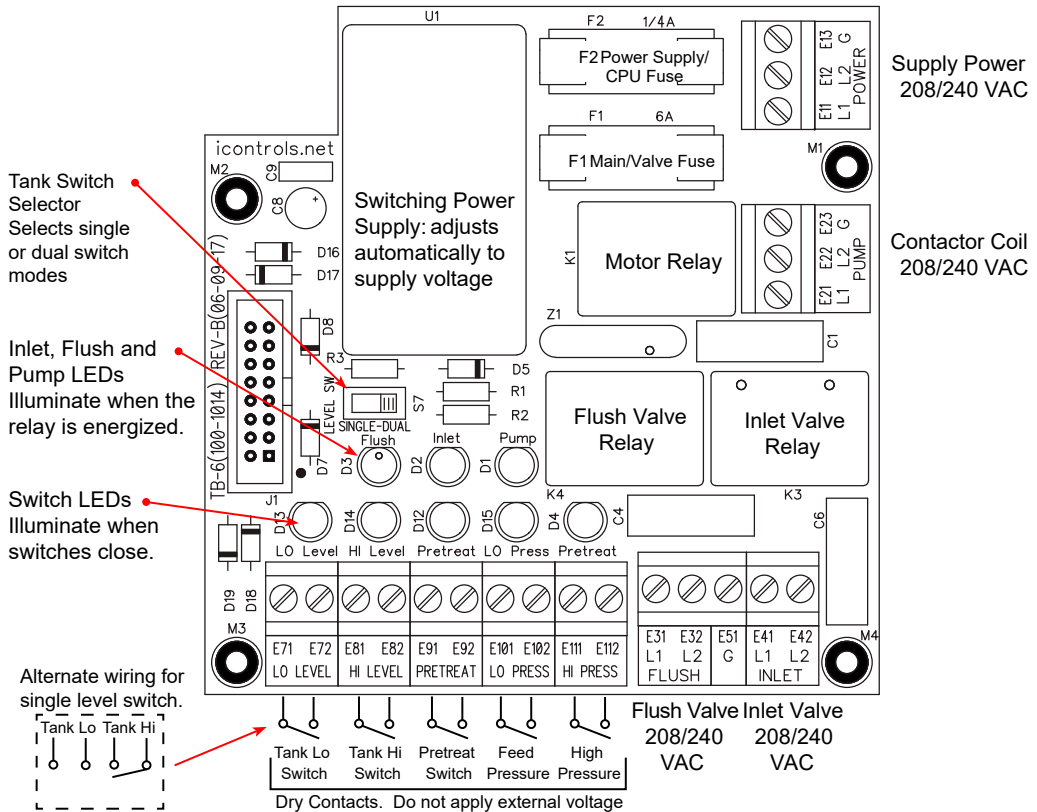
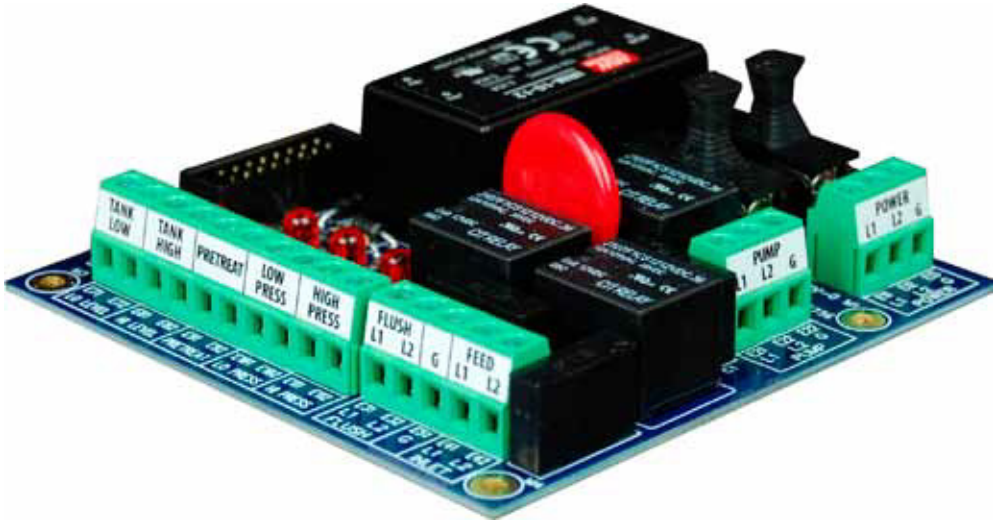



## Figure 5 - Conductivity Probe Installation

Install the Conductivity Probe in the "Run" of a Tee or equivalent location. Orient the probe so that air can not become trapped in the area near the probe.

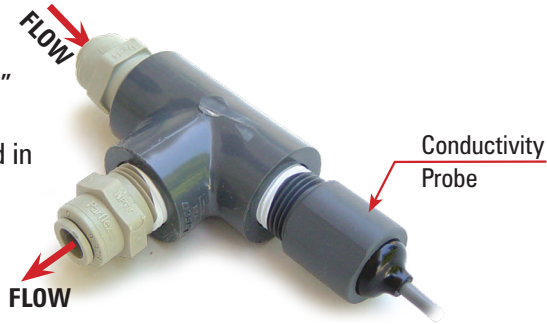

## Installation

- 1 Drill the enclosure as needed and install liquid-tight fittings for the wiring.



**NOTE:** *The Controller can be ordered pre-drilled or with fittings installed, or with fittings and wiring installed. Contact Nelsen Corporation for details.*

- 2 Mount the enclosure in the desired location on the RO system.
- 3 Bring the wires from the peripheral devices into the enclosure and connect them to the appropriate terminals. (See Figure 1, Figure 3 and Figure 4)
- 4 Set the voltage selector switch on the Terminal Board to the desired voltage (120VAC or 240VAC) (See Figure 4)
- 5 Install the correct power fuse for your voltage/motor HP. See the table below and Figure 4.

### Controller Power Fuse Values

	.5 HP	.75 HP	1 HP	2 HP
120 VAC	12 A	20 A	20 A	N/A
240 VAC	-	-	6 A	12 A

- 6 Install the conductivity cell in the permeate line. (See Figure 5 for conductivity cell installation instructions)

- 7 Connect the conductivity cell to the terminals on the CPU Board. (See Figure 3)
- 8 Provide power to the RO system.
- 9 Press the System On/Off switch to turn the system ON.
- 10 Select the Program Mode (See Figure 6 and Table 2). The default is Program 1 which is a general purpose setting. Use Program 2 if your system is not equipped with a flush valve.



**NOTE:** *The Program Settings can be customized to suit the specific needs of an OEM and pre-programmed at the factory with your settings. Contact Nelsen Corporation for details.*

- 11 Make any other changes you want to the settings. Press System On/Off to save your changes.
- 12 The controller is now ready for service.



**NOTE:** If using a single point High Level RO water shut off/liquid level control, you need to install a **Jumper wire** on the **Terminal strip** from E24 to E26. Connect the float switch wires to terminals E23 and E26. Connection E25 is empty... no wire connection.

## Figure 6 - Controller Programming: Accessing the Hidden Menus

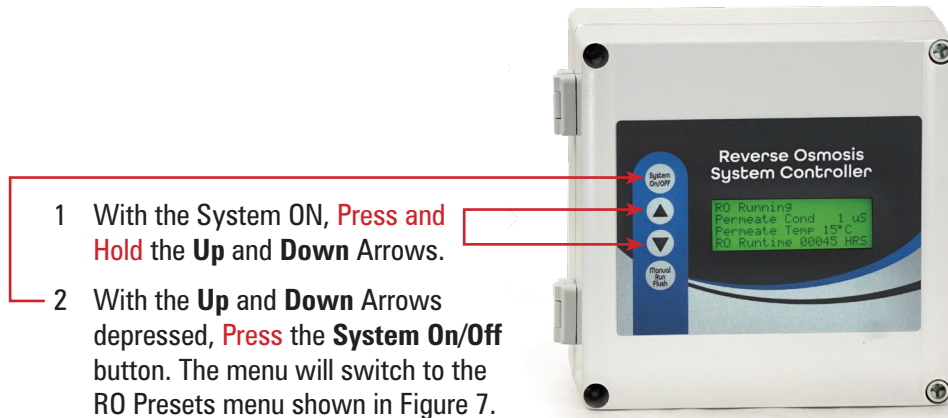

## System Start-up w/Permeate Flush

For systems equipped with a Permeate Flush, you must follow the procedure below for proper system start-up. When there is no Permeate Water in the tank the RO will not start.

1. With the system on, **Press and Hold** the **Up** and **Down** Arrows
2. With the **Up** and **Down** Arrows depressed, **Press** the **System On/Off** button. This will switch to the Hidden Menus as shown above.
3. If not already on the RO Presets Program, **Press** the **Up** or **Down** Arrows until you reach this screen.
4. Once on the RO Presets Program Screen, **Press Manual** to Edit this Screen.
5. Press the **Up** or **Down** Arrow to change to **Program 2**
6. Once on Program 2, **Press Manual** to Exit the screen.

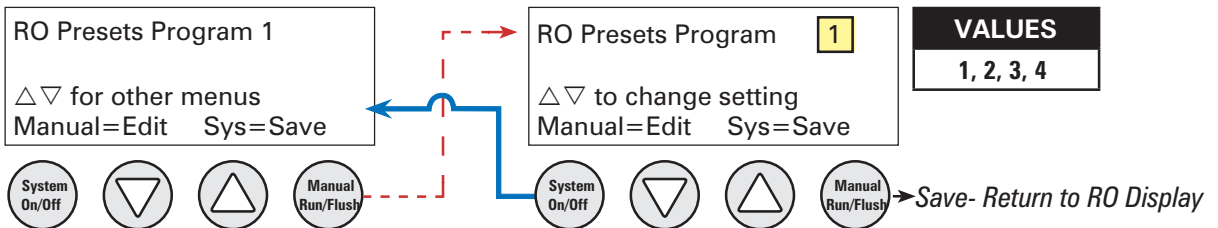

7. **Press System On/Off** to save the changes and return to the Home Page.

**Once your Permeate Tank has filled enough to do a proper permeate flush, follow the steps again changing from Program 2 back to Program 3.**

## Table 2 - Controller Programming: *ROC-2 Program Selections*

The controller has 4 separate user-selectable sets of settings for configuring the RO. The factory default settings are shown below. The settings are identical except for variations in the flush behavior.

- **Program 1, High Pressure flush**
- **Program 2, No Flush**
- **Program 3, Permeate Flush, (low pressure, inlet valve closed)**
- **Program 4, Low Pressure, feed water flush**
- See the previous page for instructions on how to access the menu for selecting these programs.
- See Appendix A for a detailed explanation of the Parameters and their affect on the RO's operation.

Parameter	Value	Program 1	Program 2	Program 3	Program 4
Tank Level Switch delay (actuation and de-actuation)	Seconds	2	2	2	2
Pressure Switch delay (actuation and de-actuation)	Seconds	2	2	2	2
Pretreat Switch delay (actuation and de-actuation)	Seconds	2	2	2	2
Pump start delay	Seconds	10	10	10	10
Inlet Solenid stop delay	Seconds	1	1	1	1
Pump start retry interval (restart delay after LP fault)	Seconds	60	60	60	60
Low pressure fault shutdown, # of faults	Faults	5	5	5	5
Low pressure fault shutdown, time period to count faults	Minutes	10	10	10	10
Low pressure fault shutdown, reset after shutdown	Minutes	60	60	60	60
Low pressure timeout fault	Seconds	60	60	60	60
<b>Flush Behavior</b>		Normal	No Flush	Extra Flush	Maximum Flush
Startup Flush: Minutes from last flush	Minutes	0	0	0	0
Startup Flush: Duration	Seconds	0	0	0	30
Periodic Flush: Interval	Minutes	60	0	0	0
Periodic Flush: Duration	Seconds	30	0	0	0
Shutdown Flush: Time from last flush	Minutes	10	0	0	0
Shutdown Flush: Minimum operation	Minutes	30	0	0	0
Shutdown Flush: Duration	Seconds	60	0	60	60
Idle Flush: Interval *	Minutes	0	0	0	0
Idle Flush: Duration *	Seconds	0	0	0	0
Timed Manual Run	Minutes	5	5	5	5
Timed Manual Flush	Minutes	5	0	5	5

\* These features are disabled by default due to the potential for confusion on the part of end-users in the field. They can be enabled when needed via the OEM PC programming interface which allows changes to all of the values shown above.

## Appendix A - Controller Programming: Parameters Explained

Parameter	Value	Range	Example
<b>Input Switch Behaviors</b>			
Tank Level Switch delay (actuation and de-actuation)	Seconds		2.0
<i>This specifies the time that the tank switch must be closed or open before the controller accepts it as a valid condition. The function is to prevent nuisance tripping of the RO especially in small tanks or turbulent tanks</i>			
Pressure Switch delay (actuation and de-actuation)	Seconds		3
<i>This specifies the time that the pressure switch must be closed or open before the controller accepts it as a valid condition. Since pressure switches usually have built-in hysteresis this value is set at 0.</i>			
Pretreat Switch delay (actuation and de-actuation)	Seconds		2
<i>This is the time that the pretreat switch must be OPEN before the controller accepts it as a valid condition.</i>			
<b>Pump/Inlet Solenoid Behaviors</b>			
Pump start delay	Seconds		10
<i>On RO start-up, after the tank switch opens, the inlet solenoid valve is energized. When the inlet pressure switch closes this begins the "Pump start delay". If the pressure switch remains closed, the pump will start after 10 seconds.</i>			
Inlet Solenoid stop delay	Seconds	1	
<i>This value sets the delay for the inlet solenoid valve to be de-energized following the de-energizing of the motor on RO shut down. The purpose is to prevent the pump from operating against a closed suction as the pump spins down.</i>			
<b>Low Inlet Pressure Behaviors</b>			
Pump start retry interval (restart delay after LP fault)	Seconds		60
<i>When the inlet pressure switch opens, the controller de-energizes the motor and the inlet solenoid valve remains open. The controller will continue to monitor the inlet pressure switch. After the switch is closed for the duration of the "Pump start retry interval" the motor is reenergized.</i>			
Low pressure fault shutdown, # of faults	Faults		5
Low pressure fault shutdown, time period to count faults	Minutes		10
Low pressure fault shutdown, reset after shutdown	Minutes		60
<i>These three values work together to determine how the RO handles Low Pressure conditions. The first two values, "# of faults" and "time period to count faults", sets the limit for the number of low fault conditions over time that are required to place the RO in "Low Pressure Fault Shutdown". The third value sets the duration of the "Low Pressure Fault Shutdown" which is the period that the RO will remain idle before trying to restart. The purpose of the Low Pressure Fault Shutdown is to prevent an RO from turning OFF/ON repeatedly without any limit.</i>			
Low pressure time-out fault	Seconds		60
<i>If the inlet valve is open, but the pressure isn't sufficient to close the inlet pressure switch, the RO would run indefinitely on line pressure. This value sets the time limit for the RO to operate with the inlet valve open with Low Pressure as indicated by an Open inlet pressure switch before a Low Pressure Fault is added to the counter above</i>			

## Appendix A - Controller Programming: *Parameters Explained (cont.)*

Flush Behavior	Value	Range	Example
Time from last flush before Flush on Shutdown	Minutes		15
Minimum operation before Flush on Shutdown	Minutes		60
Flush duration on Shutdown	Seconds		60
Periodic Flush interval	Minutes		60
Periodic Flush duration	Seconds		30
Unit Idle Flush interval *	Minutes		0
<i>The Unit Idle Flush Interval sets a time after which the RO will start-up and run in the flush mode. This is disabled by default because of the danger of over-flowing a tank if not properly implemented. It is intended for environments where leaving the RO idle for long periods would invite bio-fouling. (0)=disabled</i>			
Unit Idle Flush duration *	Seconds		0
<i>Sets the duration of the Idle Flush. (0)=disabled</i>			
Timed Manual Run - Duration of Manual Run	Minutes		5
Timed Manual Flush - Duration of Manual Flush	Minutes		5
Conductivity Probe Sample Rate	Seconds		2
Conductivity Shutdown * (0)=disabled	Minutes		0

## Controller Fault Condition Displays

Below are examples and explanations of the displays which accompany the fault conditions possible in the ROC-3. Fault conditions always indicated a problem of some sort which requires corrective action. the displays provide sufficient information to recognize the source of the fault and the required corrective action.

**Low Pressure Fault:** *(System is responding to low pressure condition per system settings)*

Line 1 "Service Fault"

Line 2 "Low Feed Pressure"

Line 3

Line 4 "Restart in MM:SS"

**Pre Treat Fault:** *(Pretreat Switch is closed indicating problem with pretreat system).*

Line 1 "Service Fault"

Line 2 "Pretreat"

Line 3

Line 4 "Check Pretreat Sys."

## Controller Fault Condition Displays

**Permeate Conductivity Fault:** *(Permeate conductivity is higher than the alarm set-point.)*

Line 1 "Service Fault"

Line 2 "Permeate TDS xxx ppm" or "Permeate Cond xxx uS"

Line 3 "Alarm SP xxx ppm" or "Alarm SP xxx uS"

Line 4 "To Reset Push OFF/ON"

**Feed Conductivity Fault:** *(Feed conductivity is higher than the alarm set-point.)*

Line 1 "Service Fault"

Line 2 "Feed TDS xxx ppm" or "Feed Cond xxx uS"

Line 3 "Alarm SP xxx ppm" or "Alarm SP xxx uS"

Line 4 "To Reset Push OFF/ON"

**Conductivity Probe Error messages:**

Line 2 "Over-range" - Measurement is out of range for the circuit, probe may also be shorted

Line 2 "Probe shorted" - Short circuit detected on temperature sensor in probe

Line 2 "Probe not detected" - Open circuit detected on temperature sensor in probe

Line 2 "Probe Startup 1" - Internal reference voltage too high to make valid measurement

Line 2 "Probe Startup 2" - Internal reference voltage too low to make valid measurement

Line 2 "Probe Startup 3" - Internal excitation voltage too high to make valid measurement

Line 2 "Probe Startup 4", - Internal excitation voltage too low to make valid measurement

**If RO Not Working and Display Shows "Tank Full" or "Tank Full Draw Down"**

1. If using a single point high level float switch, the jumper in the wiring instructions must be installed. This needs to be checked to make sure it is not loose and or disconnected, which would cause a failure and one of the displays above. ie. Remove jumper and reinstall, making sure of a good connection. Re-check display and operation.
2. Check the switch in the tank to make sure it is operating correctly. Check the switch with a multi-meter for correct "on-off" operation. Replace switch or level control if faulty.
3. If someone connected 110v to the terminal strip connection for the high level shut off, they could have fried the "opto-isolator".
4. Also, if there were major lightning strikes and power outages with surges, it is possible that you may have had a power surge that sent electric current to the dry contacts and possibly fried the "opto-isolator". This will prevent the system from turning on, and the display will show Tank Full messages.
5. If the jumper is verified to be in place with good connections, and if the high level cut off switch in the storage tank is verified to be operational, then the board might need to be replaced due to number 3 or 4.

## Appendix B - Controller Programming: *Programming Interface Overview*

The screenshot displays the iControls - CPU4 - Sample.xml software interface, version 2.07.02. The interface is organized into several functional areas:

- File:** Includes icons for New, Open, Save, and Save As.
- Setup: RO Prog-1:** Contains icons for System, RO (selected), and WQ.
- Communications: COM6:** Includes icons for Port, Get, Send, and Status.

The main configuration area is divided into several panels:

- RO Timing:** Features a 'Timed Manual Run' set to 5 minutes, a 'Switch Debounce' section with Tank Level (2.0s), Low Pressure (2.0s), and Pretreat (2.0s) settings, and a 'Delay' section with Pump Start (10s), Low Pressure Restart (60s), and Inlet Stop (1s) settings.
- Low Pressure Behavior:** Includes Max Number of Faults (5), During Period (10 minutes), Shutdown Reset (60 minutes), and Timeout Fault (60 seconds) settings.
- Alarm/Divert Relay:** Set to 'Disable Relay' with a note to see the Water Quality menu for Divert Setpoint.
- Flush Settings:** Configured for 'High Pressure' Flush Mode. It includes:
  - Startup:** Time from last Flush (0 minutes) and Duration (0 seconds).
  - Periodic (High Pressure):** Interval (60 minutes) and Duration (30 seconds).
  - Shutdown:** Time from last Flush (10 minutes), Minimum Operation (30 minutes), and Duration (60 seconds).
  - Manual:** Duration (300 seconds).
  - Idle:** Interval (0 hours) and Duration (0 seconds).
  - Delay:** Low Pressure (3 seconds) and High Pressure (0 seconds).
- Permeate Divert Dead Band:** Set to 2 seconds delay ending divert.
- WQ/Conductivity Shutdown Timer:** Set to 0 minutes shutdown, with a note to enter (0) for no shutdown.

The Programming interface is a Windows-based tool for making changes to the ROC software. This screen shows the RO settings available. There are 4 field-selectable sets of settings stored in the CPU-.4



## Appendix C - Controller Limited Warranty

### What the warranty covers:

The ROC3-HE is warranted to be free from defects in materials and workmanship during the warranty period. If a product proves to be defective during the warranty period, Nelsen Corporation will at its sole option repair or replace the product with a like product. Replacement product or parts may include remanufactured or refurbished parts or components.

### How long the warranty is effective:

The ROC3-HE is warranted for one (1) year for parts and labor from the date of the first consumer purchase or 15 months from ship date, whichever comes first.

### What the warranty does not cover:

1. Damage, deterioration or malfunction resulting from:
  - a. Accident misuse, neglect, fire, water lightning or other acts of nature, unauthorized product modification or failure to follow instructions supplied with the product.
  - b. Repair or attempted repair by anyone not authorized by Nelsen Corporation.
  - c. Any damage of the product due to shipment.
  - d. Causes external to the product such as electric power fluctuations.
  - e. Use of supplies or parts not meeting i-Controls' specifications.
  - f. Normal wear and tear.
  - g. Any other cause which does not relate to a product defect.
2. Transportation costs necessary to obtain service under this warranty.
3. Labor other than factory labor.

### How to get service:

1. To obtain warranty service, contact your selling dealer for a Return Material Authorization (RMA).
2. You will be required to provide:
  - a. Your name and address
  - b. A description of the problem
3. Package the controller carefully for shipment and return it to your, freight prepaid.

### Limitation of implied warranties:

There are no warranties, expressed or implied, which extend beyond the description contained herein including the implied warranty of merchantability and fitness for a particular purpose.

### Exclusion of damages:

Liability is limited to the cost of repair or replacement of the product. Nelsen Corporation shall not be liable for:

1. Damage to other property caused by any defects in the product, damages based upon inconvenience, loss of use of the product, loss of time, loss of profits, loss of business opportunity, loss of goodwill, interference with business relationships or other commercial loss, even if advised of the possibility or such damages.
2. Any other damages, whether incidental, consequential or otherwise.
3. Any claim against the customer by any other party.

### Effect of state law:

This warranty gives you specific legal rights, and you may also have other rights which vary from state to state. Some states do not allow limitations on implied warranties and/or do not allow the exclusion of incidental or consequential damages, so the above limitations and exclusions may not apply to you.